

Technical data

**Oil / Air Cooling Unit
2.7807.2. - .**

Size 07 AC

Issue 2000

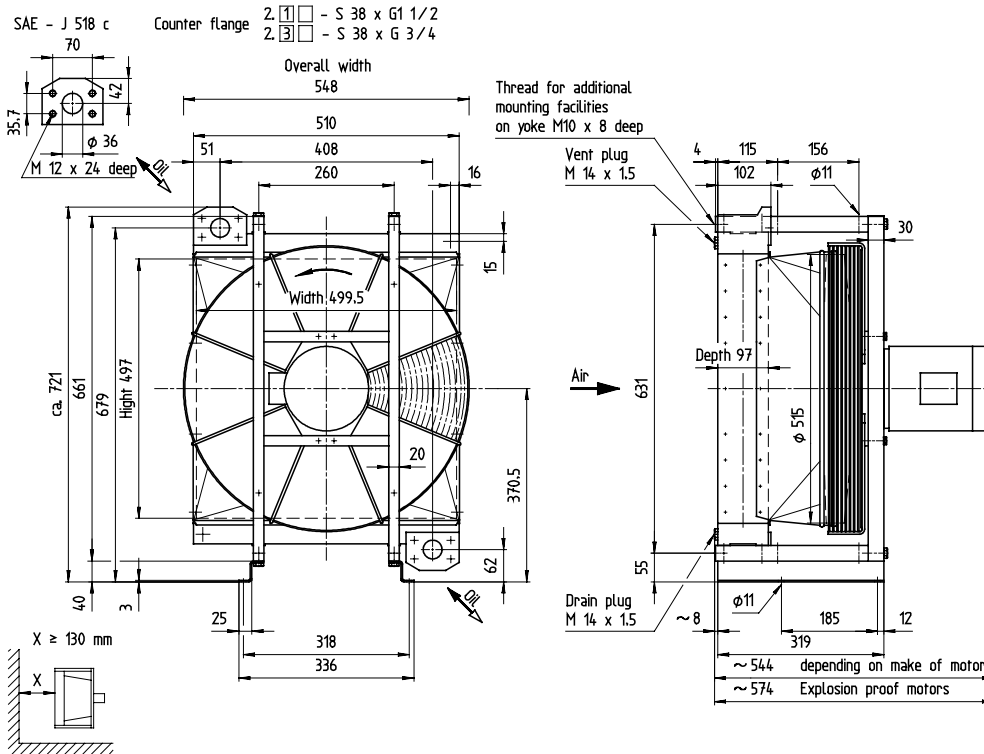

At surface temperatures of more than 80°C, protection against accidental contact should be guaranteed in the working area

Details are subject to modification without notice!

Application	Cooling of oil, HFA,HFB, HFC, HFD - fluids up to $v \approx 100 \cdot 10^{-6} \text{ m}^2/\text{s}$ ($\hat{=} 100 \text{ cSt}$), Water/Glycol 65:35, no water without corrosion preventive (min. 2 %). Cooling medium: Air				
Technical data	Type	2.7807.2. -	51.	31.	11.
	Face area	m ²	0,25	0,25	0,25
	Fan speed	1/min	1500	1000	750
	Fan load	kW	0,46	0,18	0,04
	Air flow	kg/s	1,2	0,7	0,5
	Noise level 1m/7m	dB(A)	82 / 70	70 / 58	62 / 50
	from 63 Hz to 8000 Hz		< 8 Bel; < N 80	< 7 Bel; < N 70	< 6 Bel; < N 60
	Motor power	kW	0,75	0,55	0,25
	Motor frame size		IM B14 C120 - 80	IM B14 C120 - 80	IM B14 C120 - 80
Total weight with motor	kg	46,4	46,4	46,4	
Weight without motor	kg	37	37	37	
Oil content	l	6,2	6,2	6,2	
Max. working pressure	16 bar				
Max. working temp.	Oil and hydraulic fluids 120 °C, water/glycol, emulsion 90 °C With explosion-proofed motor oil 100 °C, hydraulic fluids 90 °C				
Material	Cooler: Aluminium	Fan shroud: Steel (zinc plated)			
	Fan: Plastic	Other parts: Steel (zinc plated)			
Installation instruction	Refer to: Type sheet, operation instructions Ensure there is an unhindered flow of air to and from the cooler. Provide ventilation and exhaust in room where cooler is installed. Avoid a pulsating oil flow and pressure surges.				
Type key	<div style="text-align: center;"> 2 . 7 8 0 7 . 2 . - . </div> <p>Size of unit Variant (key number)</p> <p>Number of passes (normal: 1, for low oil flows:)</p> <p>Position of oil connections, direction of air flow, Type of fan drive and fan speed</p>				
Accessories	in price	2 SAE – counter flange with gaskets and screws			
	charged extra	Filter mats for oil / air coolers Temperature regulator for tank installation			
Performance	see overleaf				

Introduction

Following data are known:

Dissipation loss P_V [kW]
 Oil flow \dot{V}_{Oil} [l/min]
 Max. perm. oil temperature t_{OIE} [°C]
 Cooling air temperature t_{LE} [°C]

From the following can be calculated:

Entry - Temperature - Difference
 $ETD = t_{OIE} - t_{LE}$ [K]
 Specific cooling capacity with ETD = 1 K
 $P_{01} = \frac{P_V}{ETD}$ [kW/K]

In hydraulic systems, the dissipation loss is approximately 20 – 25 % of drive power.

Performance diagrams

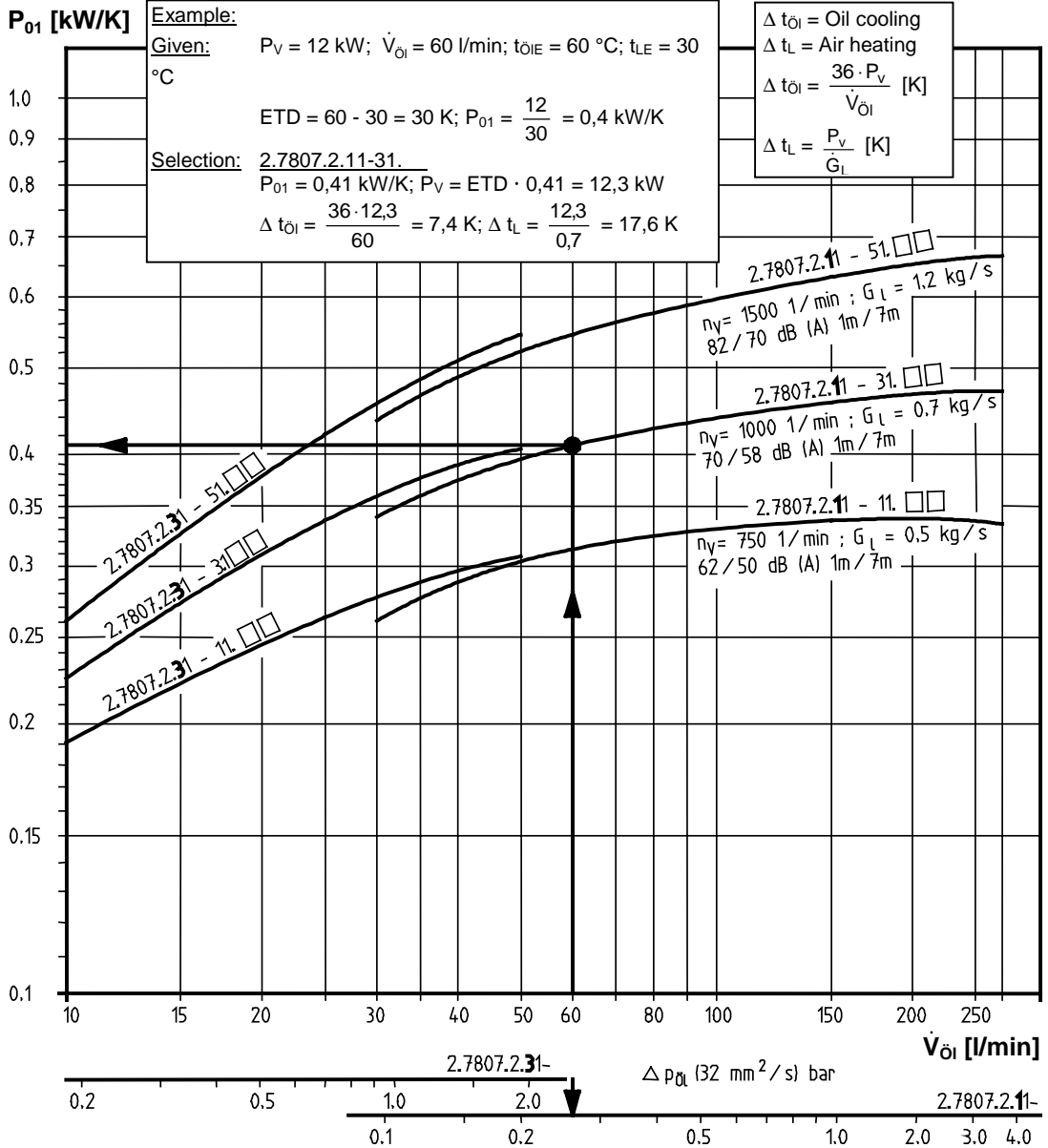

Δp_{O1} - Correction

The Δp -value obtained from the curves applies for $\nu = 32$ mm²/s ($\cong 32$ cSt).

For differing viscosities, the Δp -value has to be multiplied by the factor f.

10	15	20	32	40	50	60	80	100	150	200	250	300	400	500	mm ² /s
0,5	0,65	0,75	1,0	1,2	1,4	1,6	2,1	2,7	4	5,5	7,3	9,5	16	30	f