

Technical data

**Oil / Air Cooling Unit
2.7814.2.□□ - □□.□□**

Size 14 AC

Issue 2000

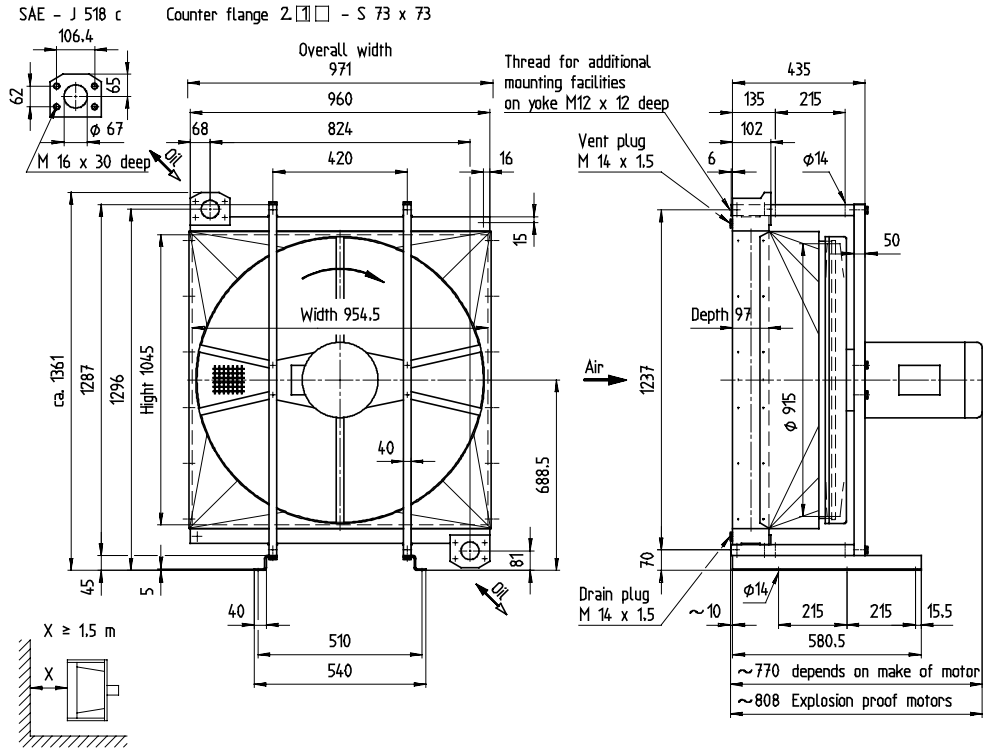

At surface temperatures of more than 80°C, protection against accidental contact should be guaranteed in the working area

Details are subject to modification without notice!

| | | | | |
|--------------------------|---|--|-----------------|-----------------|
| Application | Cooling of oil, HFA,HFB, HFC, HFD - fluids up to $v \approx 100 \cdot 10^{-6} \text{ m}^2/\text{s}$ ($\approx 100 \text{ cSt}$), Water/Glycol 65:35, no water without corrosion preventive (min. 2 %). Cooling medium: Air | | | |
| Technical data | Type | 2.7814.2.□□ - | 31.□□ | 11.□□ |
| | Face area | m ² | 1,0 | 1,0 |
| | Fan speed | 1/min | 1000 | 750 |
| | Fan load | kW | 3,1 | 1,6 |
| | Air flow | kg/s | 5,3 | 3,7 |
| | Noise level 1m/7m | dB(A) | 86 / 74 | 77 / 65 |
| | from 63 Hz to 8000 Hz | | < 8 Bel; < N 80 | < 8 Bel; < N 75 |
| | Motor power | kW | 4 | 2,2 |
| | Motor frame size | | IM B5 - 132M | IM B5 - 132S |
| Total weight with motor | kg | 189 | 184 | |
| Weight without motor | kg | 133 | 133 | |
| Oil content | l | 20 | 20 | |
| Max. working pressure | 16 bar | | | |
| Max. working temp. | Oil and hydraulic fluids 120 °C, water/glycol, emulsion 90 °C With explosion-proof motor oil 100 °C, hydraulic fluids 90 °C | | | |
| Material | Cooler: Aluminium | Fan shroud: Steel (zinc plated) | | |
| | Fan: Plastic | Other parts: Steel (zinc plated) | | |
| Installation instruction | Refer to: Type sheet, operation instructions Ensure there is an unhindered flow of air to and from the cooler. Provide ventilation and exhaust in room where cooler is installed. Avoid a pulsating oil flow and pressure surges. | | | |
| Type key | <div style="text-align: center;"> 2 . 7 8 1 4 . 2 . 1 □ - □□ . □□ </div> <div style="display: flex; justify-content: space-around; margin-top: 10px;"> <div style="text-align: center;"> Size of unit Number of passes Position of oil connections, direction of air flow, finish </div> <div style="text-align: center;"> Variant (key number) Type of fan drive and fan speed </div> </div> | | | |
| Accessories | in price | 2 SAE – counter flange with gaskets and screws | | |
| | charged extra | Filter mats for oil / air coolers Temperature regulator for tank installation | | |
| Performance | see overleaf | | | |

Introduction

Following data are known:

Dissipation loss P_V [kW]
 Oil flow \dot{V}_{Oil} [l/min]
 Max. perm. oil temperature t_{OIE} [°C]
 Cooling air temperature t_{LE} [°C]

From the following can be calculated:

Entry - Temperature - Difference
 $ETD = t_{OIE} - t_{LE}$ [K]
 Specific cooling capacity with ETD = 1 K
 $P_{01} = \frac{P_V}{ETD}$ [kW/K]

In hydraulik systems, the dissipation loss is approximately 20 – 25 % of drive power.

Performance diagrams

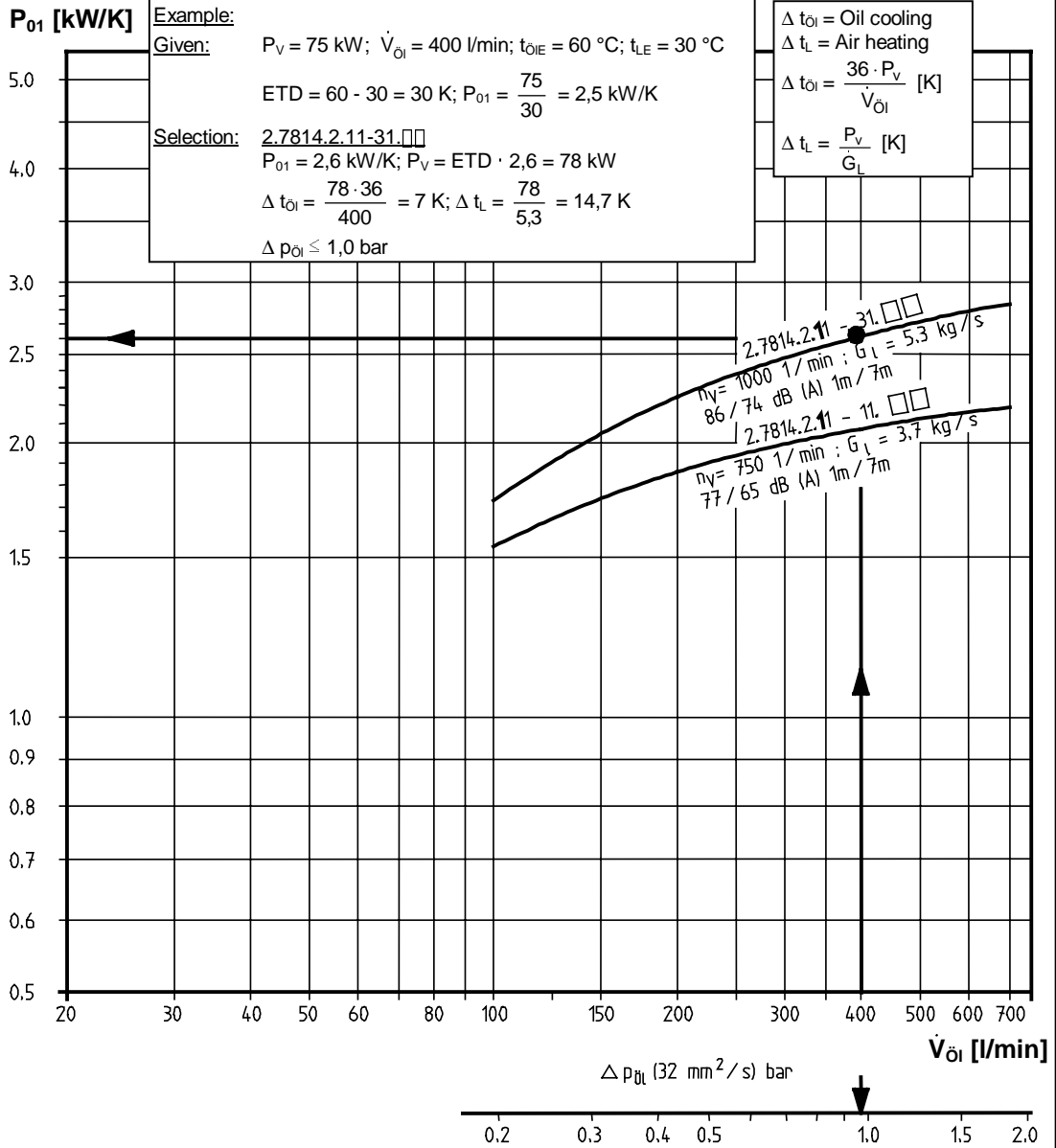

Δp_{Oil} - Correction

The Δp -value obtained from the curves applies for $\nu = 32$ mm²/s ($\hat{=} 32$ cSt).
 For differing viscosities, the Δp -value has to be multiplied by the factor f.

| | | | | | | | | | | | | | | | |
|-----|------|------|-----|-----|-----|-----|-----|-----|-----|-----|-----|-----|-----|-----|--------------------|
| 10 | 15 | 20 | 32 | 40 | 50 | 60 | 80 | 100 | 150 | 200 | 250 | 300 | 400 | 500 | mm ² /s |
| 0,5 | 0,65 | 0,75 | 1,0 | 1,2 | 1,4 | 1,6 | 2,1 | 2,7 | 4 | 5,5 | 7,3 | 9,5 | 16 | 30 | f |